

ANDRITZ

Vertical volute pumps



Customer-specific pump engineering

Solutions for customer needs

For over 100 years, ANDRITZ has been a byword for competence and innovation in building centrifugal pumps.

Extensive experience and great flexibility in accommodating our customers' needs have made ANDRITZ a preferred partner on a global scale. From R&D, to design and manufacture, to after-sales-service, ANDRITZ combines the entire value added chain under one roof.

Fields of application

- In water transport for ...
 - irrigation and drainage
 - drinking and industrial water supplies
- In the power industry as ...
 - cooling water pumps for power stations
- In seawater desalination for ...
 - seawater intake pumps

Materials competence

ANDRITZ pumps transport many different media. The pumps must have various properties, depending on the medium concerned. That is why choice of material and suitable finishing are the determining factors for functioning and stability of the pump.

Different materials are used depending on the service conditions and customer requirements: cast iron, cast steel, non-alloyed and low-alloyed steel grades, stainless CrNi steel grades, Duplex and Superduplex steel grades.

Design variants:

- **Design** with metal or concrete volute casing, with or without guide vane mechanism
- **Impeller** radial or semi-axial
- **Flow rate** up to 50 m³/sec
- **Head**
 - up to 40 m (concrete volute)
 - up to 250 m (metal volute)
- **Output**
 - up to 20,000 kW (concrete volute)
 - up to 50,000 kW (metal volute)



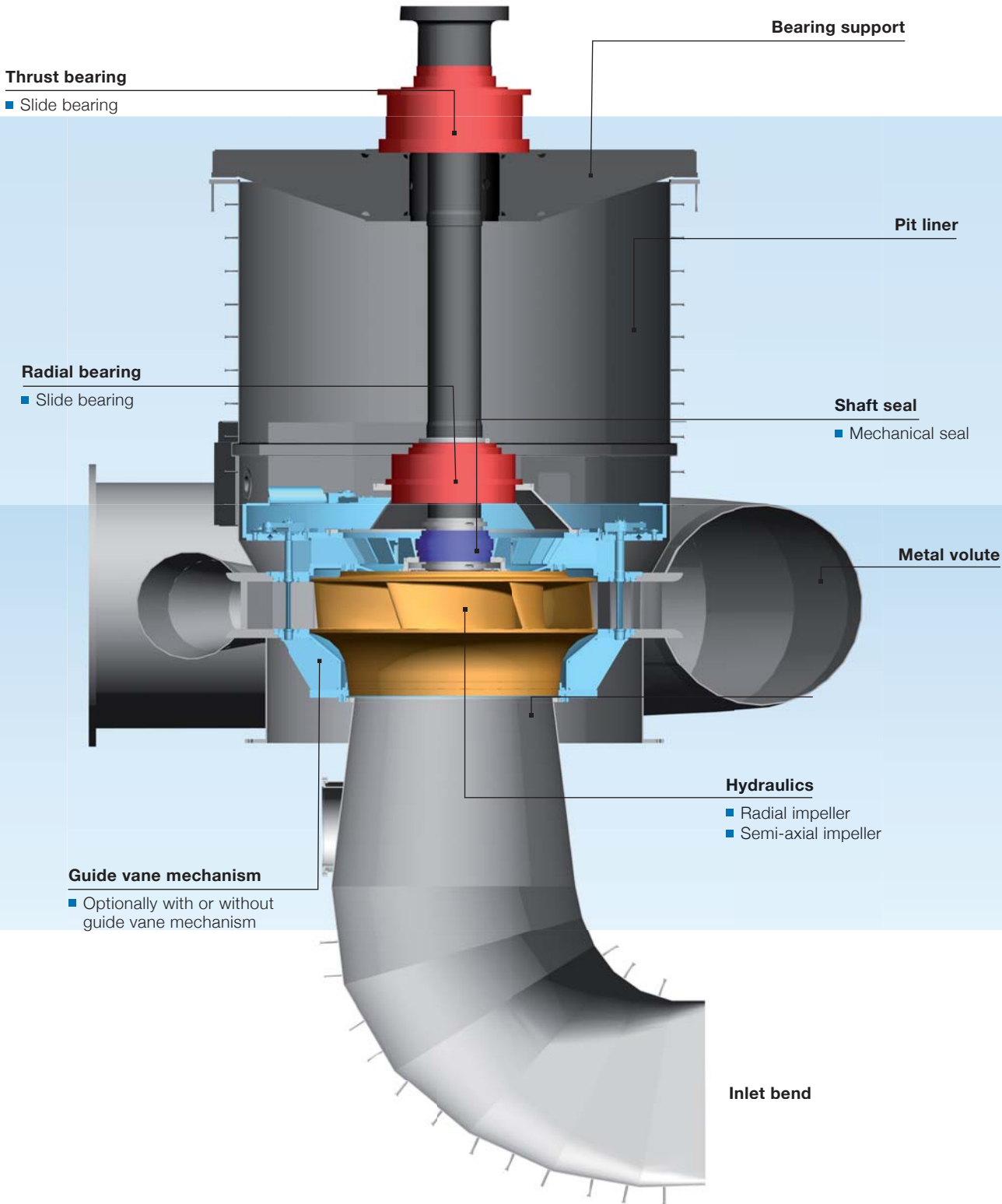

Design variants

Impeller shapes

ANDRITZ offers a complete program of impeller shapes for all combinations of delivery rates and heads, according to specific speeds. By varying the trailing edge, high-precision adjustments can be made to the desired duty points.

The impellers are designed as integral castings or are welded together, depending on the size and shape of the impeller. They are secured to the shaft flange with anti-fatigue bolts, and the force is transmitted by friction fit.

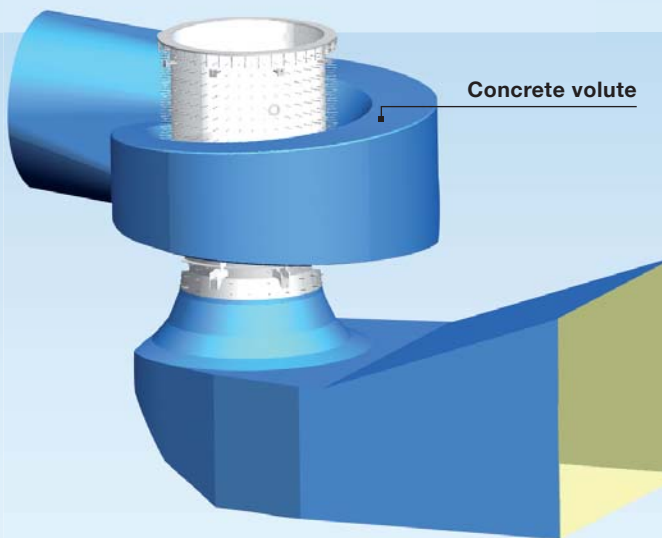
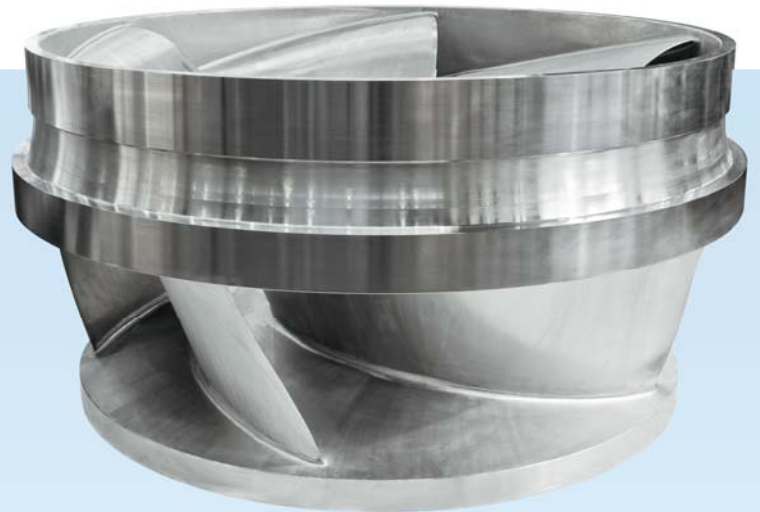

Volute casing

The hydraulic dimensioning and design of the volute casing depends on the specific output characteristics. Optimum flow is achieved in the volute thanks to its individual shaping, thus also achieving a high level of efficiency.

The volute casing is manufactured as a concrete or metal volute. The metal volute is a welded structure consisting of several segments and can be embedded in concrete as an option. This design is used primarily for larger delivery heads if a solution with a concrete volute is no longer feasible due to strength requirements.

Guide vane mechanism

The guide vane mechanism is opened and closed in a continuous process. The guide vanes are connected to the operating ring individually by means of articulated levers. This ring is actuated via hydraulic cylinders and rotates the guide vanes into the desired position.

The volute pump can be designed with or without guide vane mechanism. This component acts on the one hand as an emergency closing element if there are difficulties with the power supply. On the other hand, if synchronous motors are used the power input during start-up is kept to a minimum when the guide vanes are closed. In addition, by closing the guide vane mechanism it is also possible to start the pump while the pressure pipe is still filled. This guarantees a brief starting period with minimum power input.

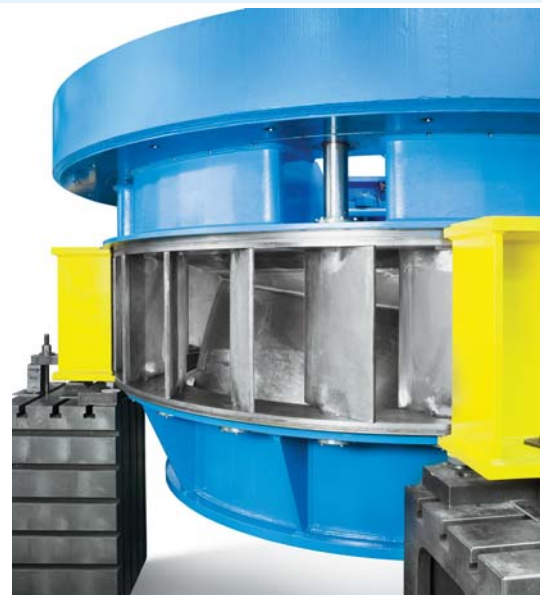

Competence to convince you

Custom-tailored solutions

ANDRITZ is a byword for customized pump solutions at the highest level. Customer-specific pumps are manufactured according to requirements and with no limits on size or flow rate.

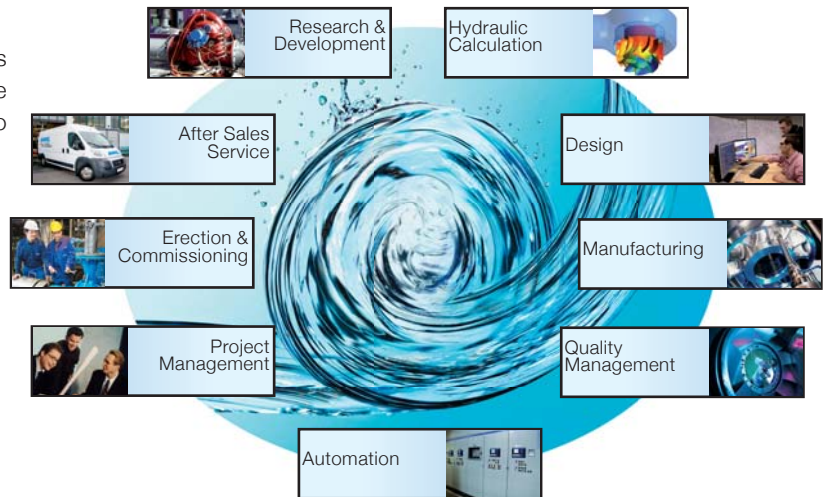

Experienced experts assist our customers with planning, development, installation, start-up and after-sales service. Engineering, design, material selection and manufacturing are conducted according to defined standards. The processes are transparent and can be adapted to individual needs.

R&D in fluid dynamics

Pumps are developed with highest efficiencies and excellent cavitation properties in our own laboratory for fluid dynamics, ASTRÖ, to meet the needs of our customers.

Efficient Development Process

Our highly qualified and experienced engineers present new developments with the latest hydraulic CFD tools, including model and inspection tests. Special peripheral conditions, such as the feed and discharge arrangement of the pumps, can be investigated and optimized.

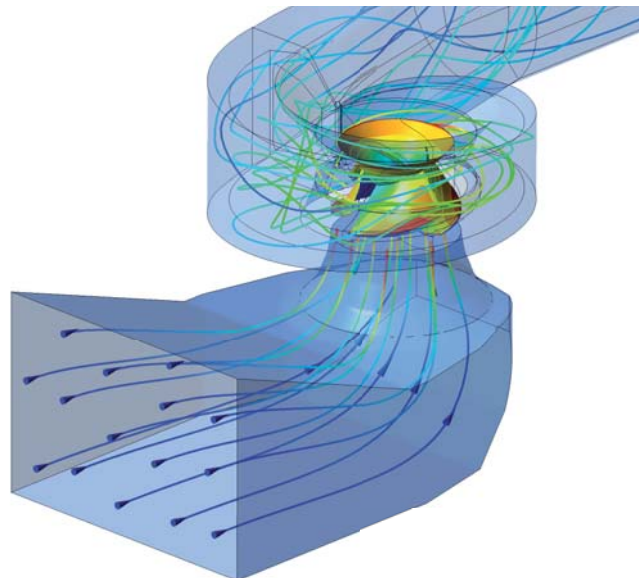

Close to our customers

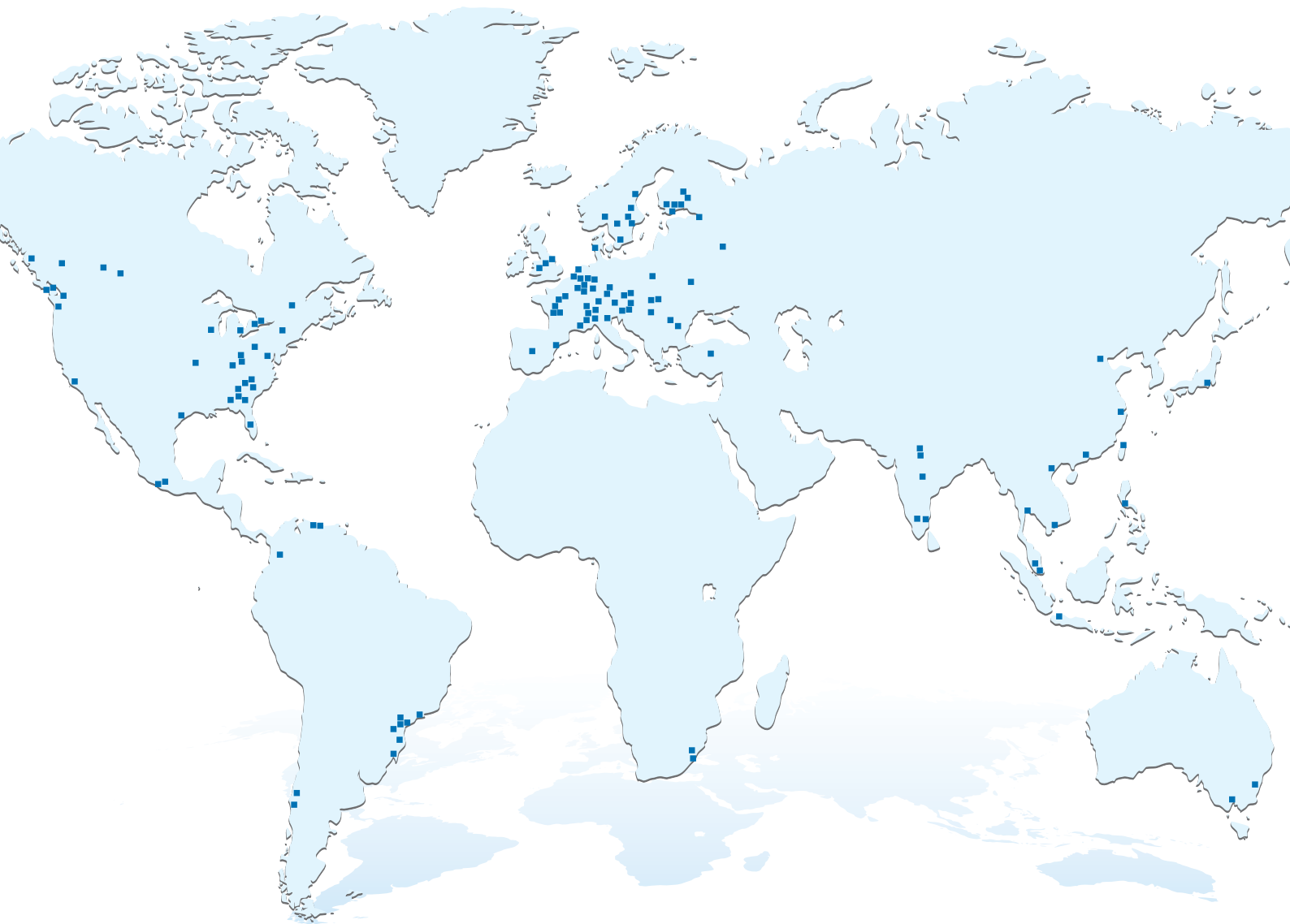
**ANDRITZ AG**

Stattegger Strasse 18
8045 Graz, Österreich
Phone: +43 (316) 6902 2133
Fax: +43 (316) 6902 406
guenter.haiden@andritz.com

www.andritz.com